

Each end of every wire is welded to the frame.

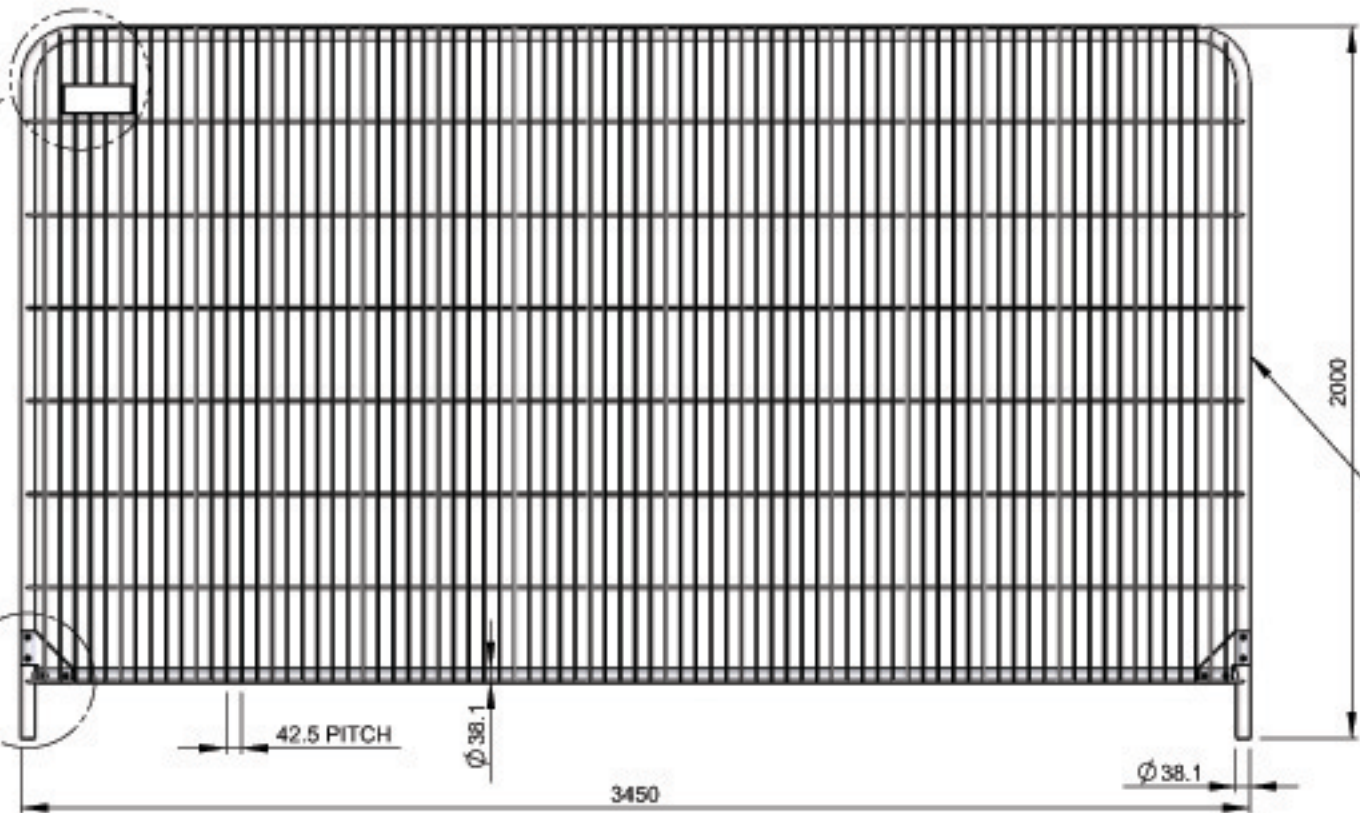

Corporate Identification



Smartweld Joint

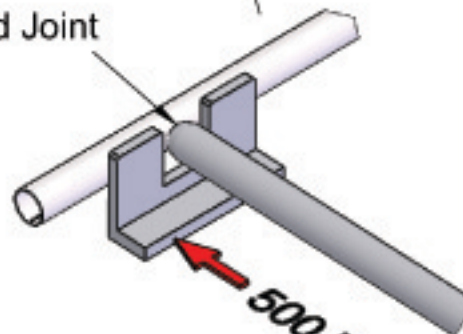

Each tube butt weld is tested to 500 Kg load before fitting the corner plates.

DEBUR AND BREAK SHARP EDGES



Every panel is marked with a proof of load test code showing date and time of test.

REV	DATE	DESCRIPTION	DRN	CHKD	APPR
5	10/8/10	ISSUED FOR INFORMATION	GC		

**SMARTWELD 100
ANTI-CLIMB ROUND TOP PANEL**

FIRST ANGLE PROJECTION
DO NOT SCALE DRAWING
UNLESS OTHERWISE SPECIFIED
DIMENSIONS ARE IN MILLIMETERS
TOLERANCES:
FINISH: 0.10mm
WELD: 0.10mm
HOLE: 0.10mm
DIPLOM: 0.10mm

NO.	NAME	SIGNATURE	DATE	MATERIAL
01	G. CRICK		19/09	CARBON STEEL
02				
03				
04				
05				

FINISH: PRE-GALVANISED TO BS EN 10244-2
WEIGHT: 17 Kg



07052232 - SPEC

5